



INSTRUCTION MANUAL

Model GLD-SDO

LS-Drive

GLD-SDO
LS-Drive Operator

GLD-R2.5M
Rail for (max) 2.5m High Door

GLD-R3.0M
Rail for (max) 3.0m High Door

OPERATOR
SUPPLIED WITH GRIFCO
MONITORED ENTRAPMENT
PROTECTION



Commercial Sectional Door Operator

- THIS OPERATOR IS TO BE INSTALLED AND SERVICED BY A TRAINED TECHNICIAN ONLY
- Compatible with Security+ 2.0[®] accessories
- Compatible with Grifco Battery Backup and myQ Internet Gateway

Chamberlain Australia Pty Ltd
Unit 1, 75 Epping Rd North Ryde NSW 2113
Ph: 1800 GRIFCO
www.grifco.com.au

Ref: 114A4934H

GRIFCO[®]

SAFETY SYMBOL AND SIGNAL WORD REVIEW

This commercial sectional door operator has been designed and tested to offer safe service provided it is installed, operated, maintained and tested in strict accordance with the instructions and warnings contained in this manual.



WARNING



Mechanical
WARNING

Electrical

CAUTION

When you see these Safety Symbols and Signal Words on the following pages, they will alert you to the possibility of serious injury or death if you do not comply with the warnings that accompany them. The hazard may come from something mechanical or from electric shock.

When you see this Signal Word on the following pages, it will alert you to the possibility of damage to your commercial door and/or the commercial door operator if you do not comply with the cautionary statements that accompany it.

THESE ARE IMPORTANT SAFETY INSTRUCTIONS. FOLLOW ALL INSTRUCTIONS AS INCORRECT INSTALLATION CAN LEAD TO SEVERE INJURY OR DEATH



Keep commercial door balanced. Sticking or binding doors must be repaired. Commercial doors, door springs, pulleys, brackets and their hardware are under extreme tension and can cause serious personal injury. Do not attempt to loosen, move or adjust them. Call for commercial door service.



Do not wear rings, watches or loose clothing while installing or servicing a commercial door operator.



To avoid serious personal injury from entanglement, remove all ropes connected to the commercial door before installing the door operator.



Installation and wiring must be in compliance with your local building and electrical codes. Connect the power supply cord only to properly earthed mains.



Moisture and water can destroy the electronic components. Make sure under all circumstances that water moisture or storage moisture cannot penetrate the electronics. The same applies for openings and cable entries.



After the installation a final test of the full function of the system and the full function of the safety devices must be done.



When operating a biased-off switch, make sure that other persons are kept away.



The operator cannot be used with a driven part incorporating a wicket door (unless the operator cannot be operated with the wicket door open).



Motor may become hot during operation. Appropriate clearance and/or shielding should be supplied by the installer to ensure any cabling, wiring and/or other items cannot come in contact with the motor. If temperature rise exceeds 50°C all fixed wiring insulation must be protected, for example, by insulating sleeving having an appropriate temperature rating.



If the supply cord is damaged, it must be replaced by the manufacturer, its service agent or similarly qualified persons in order to avoid a hazard.



Do not allow children to play with operator wall controls or remote controls. Keep remote controls away from children.



Permanently fasten all supplied labels adjacent to the wall control as a convenient reference and reminder of safe operating procedures.



Disengage all existing commercial door locks to avoid damage to commercial door. Install the wall control (or any additional push buttons) in a location where the commercial door is visible during operation. Do not allow children to operate push button(s) or remote transmitter(s). Serious personal injury from a closing commercial door may result from misuse of the operator.



Activate operator only when the door is in full view, free of obstructions and operator is properly adjusted. No one should enter or leave the building while the door is in motion.



An electrician must disconnect electric power to the commercial door operator before making repairs or removing covers.



The actuating member of a biased-off switch is to be located within direct sight of the door but away from moving parts. Unless it is key operated, it is to be installed at a minimum height of 1500mm and not accessible to the public.



Make sure that people who install, maintain or operate the door follow these instructions. Keep these instructions in a safe place so that you can refer to them quickly when you need to.



This appliance is not intended for use by persons (including children) with reduced physical, sensory or mental capabilities, or lack of experience and knowledge, unless they have been given supervision or instruction concerning use of the appliance by a person responsible for their safety. Children should be supervised to ensure that they do not play with the appliance.



Use the commercial sectional door operator for its intended purpose. The GLD-SDO operator is designed lifting spring-balanced sectional doors.



WARNING! Product includes wireless transmitters and wall controls that contain coin/button cell batteries. Keep wireless devices and batteries away from children. Battery can cause severe or fatal injuries in 2 hours or less if swallowed or placed inside any part of the body. Seek immediate medical attention if it is suspected that a coin/button cell battery has been swallowed or placed inside any part of the body.



WARNING: Important safety instructions
It is important for the safety of persons to follow all instructions.
SAVE these instructions

INTRODUCTION

CONTENTS

SAFETY SYMBOL AND SIGNAL WORD REVIEW	2
INTRODUCTION	3
OPERATOR SPECIFICATIONS	4
OPERATOR OVERVIEW	5
CONTROL PANEL OVERVIEW	5
CARTON INVENTORY	6
TOOLS REQUIRED	6
HARDWARE PROVIDED	6
INSTALLATION	7
CONNECT RAIL TO OPERATOR	7
TIGHTENING THE CHAIN	7
FASTENING RAIL TO OPERATOR	7
HEADER BRACKET POSITIONING	8
INSTALL HEADER BRACKET	8
POSITION THE OPERATOR	9
MOUNT THE OPERATOR TO THE CEILING	9
FASTEN THE DOOR BRACKET	9
ATTACH DOOR ARM TO TROLLEY	10
TESTING AND OPERATING THE MANUAL RELEASE	10
COMMISSIONING	11
PROGRAMMING TRAVEL LIMITS AND FORCE SETTINGS	11
INSTALL THE ENTRAPMENT PROTECTION SYSTEM	12
SETTING TIMER-TO-CLOSE (TTC)	13
ATTACHING BATTERY BACKUP UNIT (OPTIONAL)	13
TYPES OF SECURITY +2.0 TRANSMITTERS	14
COMMISSIONING REMOTE TRANSMITTERS	14
COMMISSIONING myQ	15
COMMISSIONING Fire OPEN Input	15
MAINTENANCE AND CARE	15
USING YOUR OPERATOR	16
CARE OF YOUR OPERATOR	16
ACCESSORIES	17
TROUBLESHOOTING	17
DIAGNOSTICS	18
SERVICE AND REPAIR PARTS	19
CHAMBERLAIN LIMITED WARRANTY	20

INTRODUCTION

OPERATOR SPECIFICATIONS

Power Specifications			
Main AC Power Supply	230-240 Vac 50Hz		
Max. Pull Force	1,200N		
Power	225W		
Operating Temperature	+5°C to +40°C		
Door Specifications			
Max Door Height	3.0m		
Max Door Weight	160kg		
Max Lift under Spring Tension	20kg		
Normal Torque	8Nm		
Maximum Door Area	Commercial Spring-Balanced Sectional Doors up to 15m ²		
Max. Door Cycles	50 cycles / day		
Dimensions			
Operator Length	370mm	Rail Length	GLD-R2.5m: 3,822mm / GLD-R3.0M: 4,322mm
Operator Height	100mm	Rail Height	46.5mm
Operator Width	200mm	Rail Width	88mm
Total installed dimensions	GLD-SDO-R2.5M: 3,972mm (L) x 150mm (H) x 200mm (W) GLD-SDO-R3.0M: 4,472mm (L) x 150mm (H) x 200mm (W)		
Compliance	AS/NZS 60335-1 AS/NZS 60335-2-103		
Transmitter Specifications			
Hand Transmitters	64 devices		
Keypad Transmitters	2 devices		
Operator Frequency	433.30 / 433.92 / 434.54 MHz		
Transmitter Management	Compatible with STAR1000EVO (accessory sold separately)		
Usage	Indoor Use Only		

TYPICAL DOOR INSTALLATION

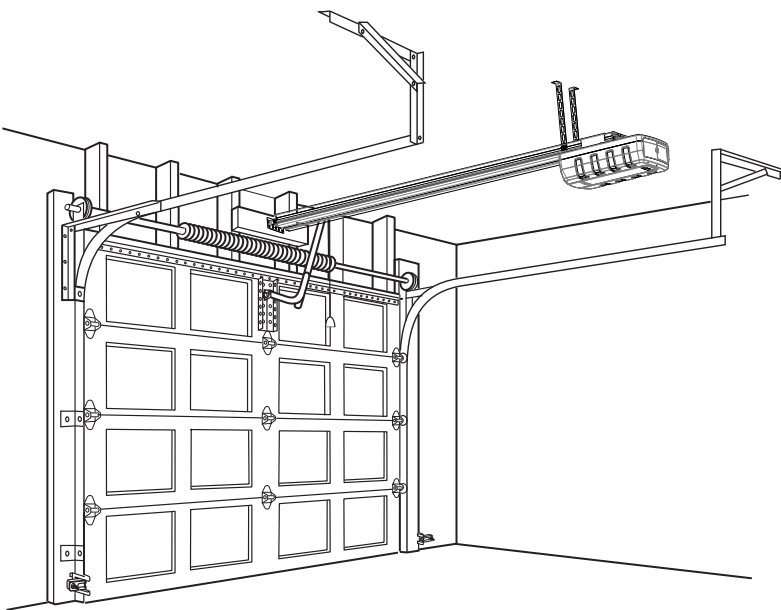

Door Types

Commercial spring-balanced sectional door with curved track, up to 3.0m high and up to 15m² in area.

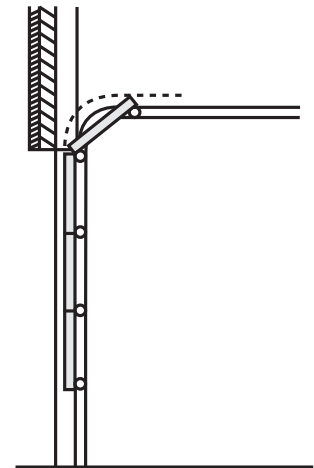

A 240V General Purpose Outlet (GPO) ie. Power Point must be available in close proximity to the operator.
This fitting is not part of the operator hardware and must be supplied by the consumer.

INTRODUCTION

OPERATOR OVERVIEW

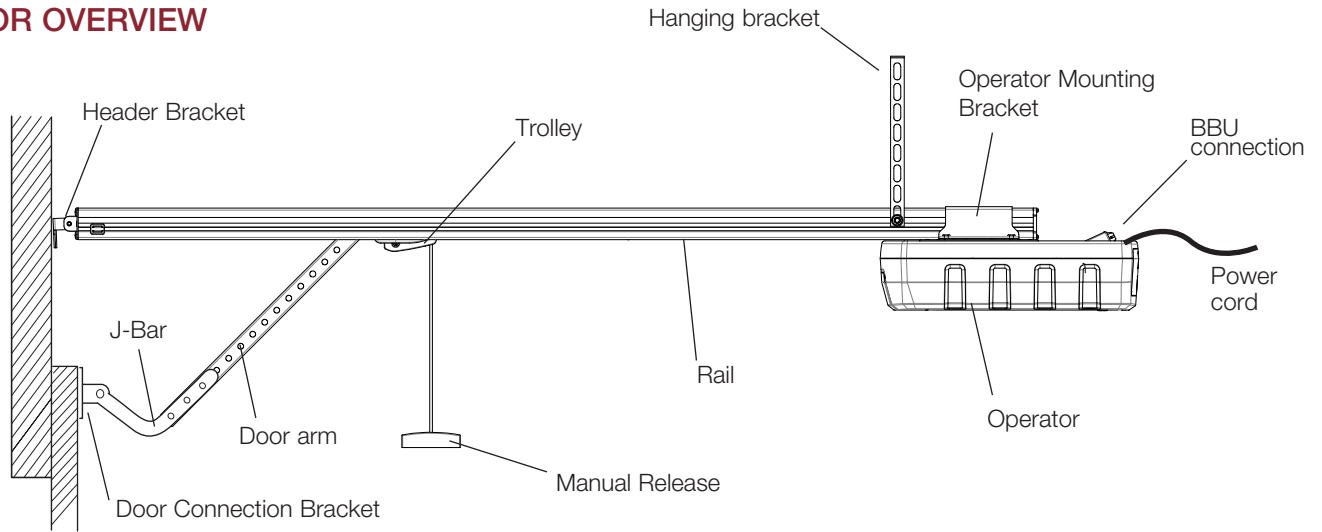

CONTROL PANEL OVERVIEW

Control Panel is accessible under the cover on the rear of the operator.

1.	Up Button	Used for initial programming, driving the door up and for displaying diagnostic codes - Digit 1
2.	Prog Button	Used to program door limits and other features
3.	Down Button	Used for initial programming, to drive the door down and for displaying diagnostic codes - Digit 2
4.	Learn Button	Used for programming remote access devices, myQ and manual learning of forces
5.	Indicator LED	Used to indicate various programming modes
6.	External Accessory Power	30 Vdc 50mA available. Constant supply
7.	Terminal Blocks	Used to configure external accessories. See chart below for the function of each terminal block.

6. External Accessory Power (30V DC)

7. Terminal Blocks

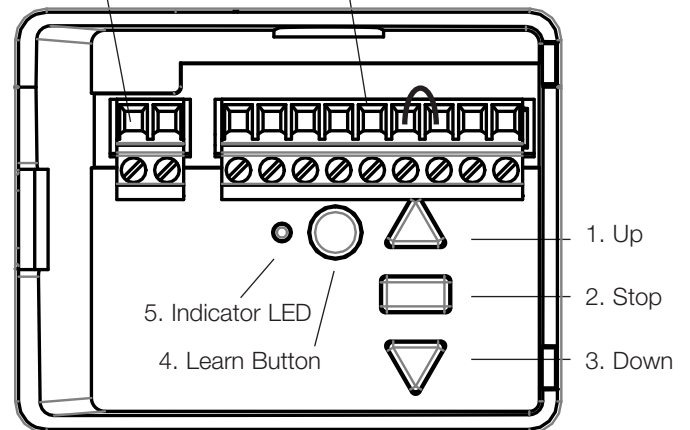

Terminal Block Functions

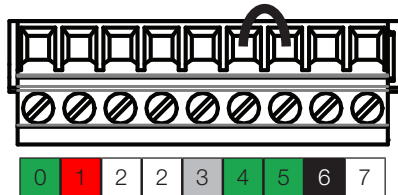

No.	Function	Colour	Polarity	Comment
0	E-Serial port	Green	+ve	Serial Communication Input
1	Trigger input	Red	+ve	Dry Contact input for access control accessories / Fire OPEN Input
2	Ground	White	-ve	Common terminal for access control accessories / Fire OPEN Input
2	Ground	White	-ve	Common terminal for Safety Beams
3	Safety Beam	Grey	+ve	Safety Beam Input: (compatible with supplied safety beams only)
4	Emergency Stop	Green	+ve	Dry Contact input for Emergency Stop N/C
5	Emergency Stop	Green	-ve	Common terminal for Emergency Stop
6	24Vdc power supply	Black	+ve	Accessory power output: (24 Vdc 150 mA) when between open and close limits (regulated)
7	24Vdc power supply	White	-ve	Accessory power output: (24 Vdc 150 mA) when between open and close limits (regulated)

INSTALLATION

CARTON INVENTORY

The commercial sectional door operator is supplied in two separate cartons.

GLD-SDO contains the operator, fitting hardware and accessories.

GLD-R2.5m or GLD-R3.0M contain the complete, assembled rail and some hardware.

GLD-BBU24V is a separate accessory, supplied in its own carton.

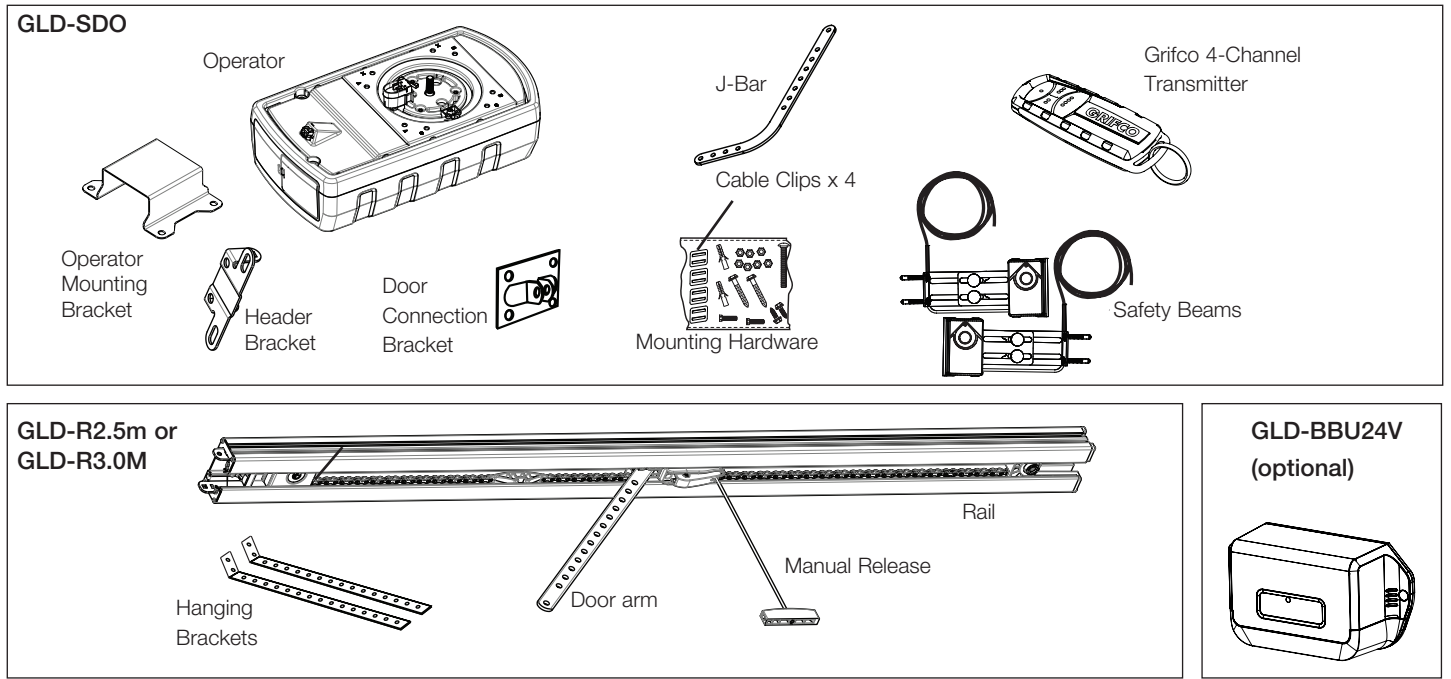

TOOLS REQUIRED

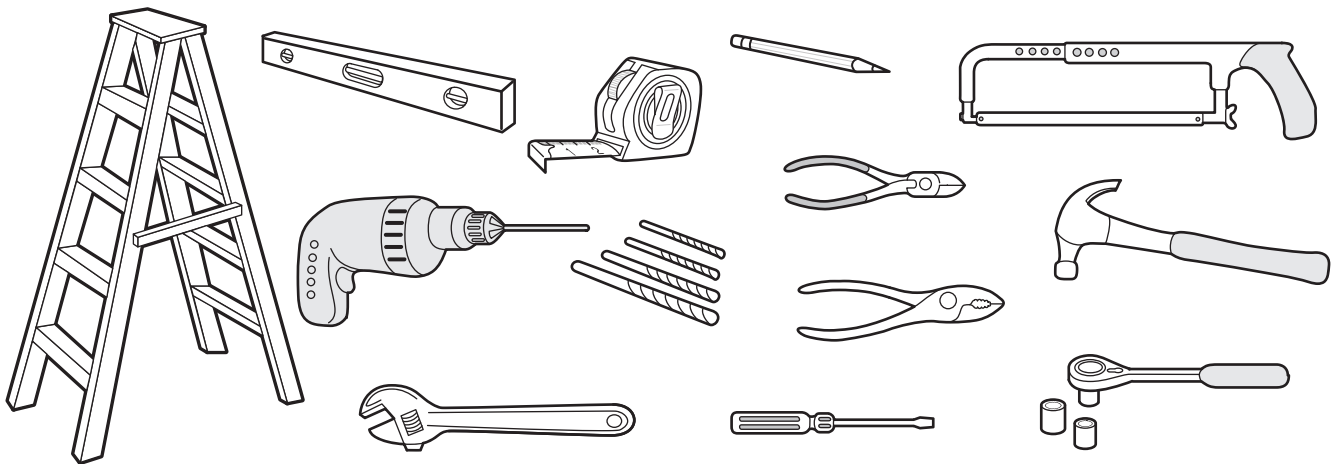

HARDWARE PROVIDED

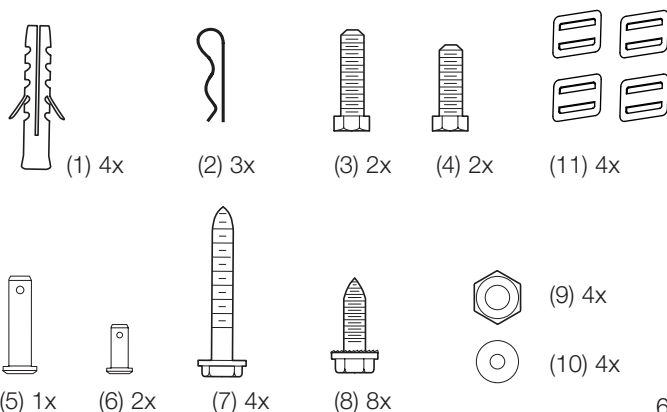

- (1) Wall plug
- (2) R clip
- (3) Hexagonal head screw M8x25
- (4) Hexagonal head screw M8x20
- (5) Clevis pin 8mm
- (6) Clevis pin 6mm
- (7) Screw ST6 x 50 mm
- (8) Screw ST6,3 x 18 mm
- (9) Nut M8
- (10) Flat washer M8
- (11) Cable Clips

INSTALLATION



WARNING

Before beginning installation of the operator check the door is in good mechanical condition, opens and closes properly and correctly balanced

STEP 1

CONNECT RAIL TO OPERATOR

Your door operator and rail are packed in two separate cartons. Remove the operator, rail and all the hardware in preparation for assembly. The chain is pretensioned from the factory, however, it is advisable to check the tension and adjust if necessary as outlined in step 2.

STEP 2

TIGHTEN THE CHAIN

Note: The spring must be able to compress and bounce during operation. Final tensioning can be performed after installation if necessary. Over tightening the chain may overload the system and cause excessive wear.

1. Tension the chain by adjusting the nut (1), on the pulley assembly, clockwise until the spring is engaged.
2. Continue tightening to compress the spring and remove all the slack in the chain. DO NOT OVERTIGHTEN but ensure chain is firm.
3. Adjust the spring to 36-38 mm as indicated in the diagram.

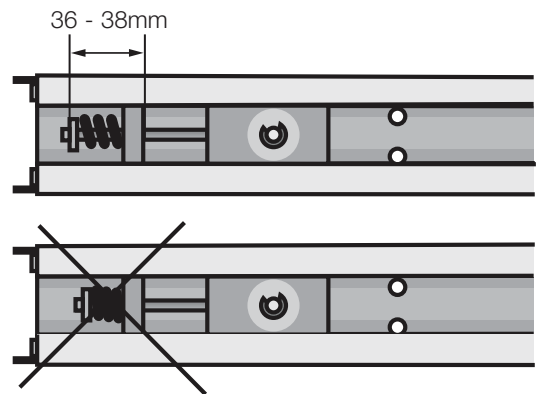

STEP 3

FASTEN RAIL TO OPERATOR

1. If using the hanging brackets to mount to ceiling, slide 1 x M8 hex head screw into either side of the rail (1). Slide screws 300mm from end of rail.
2. Position the rail drive sprocket (inside the rail) over the operator motor shaft (2) and push down to install. Ensure motor shaft adaptor (3) is in place.
3. Secure the rail on the operator with the Operator Mounting Bracket (4) using ST6,3 x 18 mm screws.

This completes the assembly of the door operator to the rail.

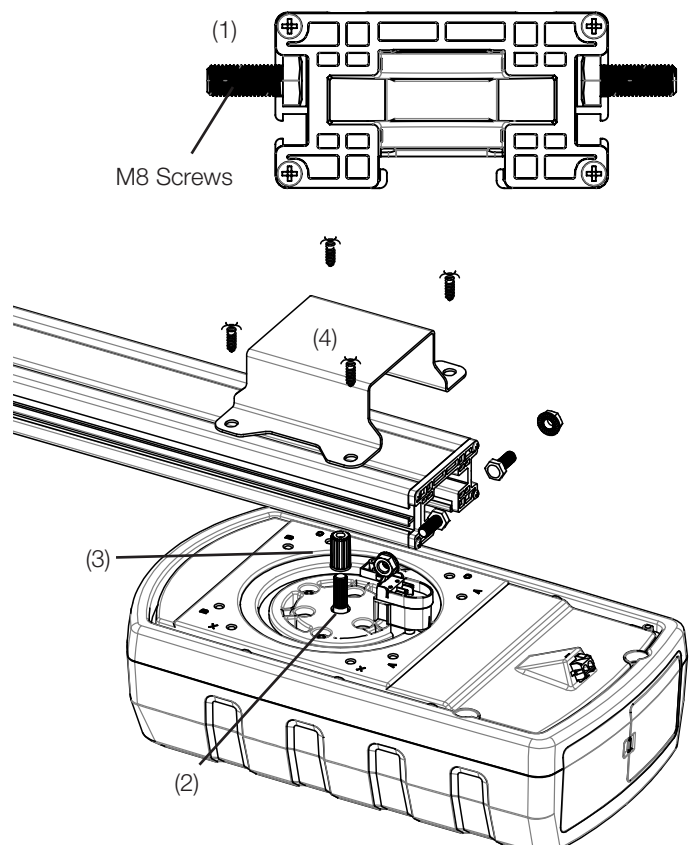

STEP 4

HEADER BRACKET POSITIONING

The header bracket must be fastened rigidly to a structural support. Reinforce the wall with a 40mm board if necessary.

With the door closed, mark the vertical centre line of the door. Extend line upward onto header wall above door.

Open door to the highest point of travel. Draw an intersecting horizontal line 50mm above door plane. This is enough space to provide travel clearance of the door beneath the rail.

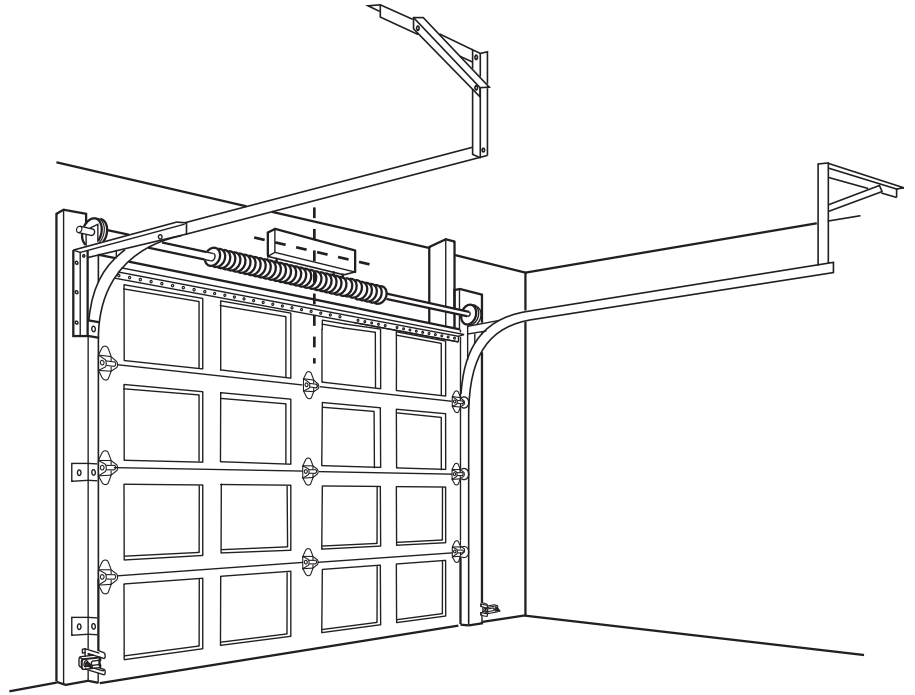

STEP 5

INSTALL HEADER BRACKET

Drill and secure the Header Bracket using the most suitable variation of holes. If using the wood screws provided, use a 4.5mm pilot drill. If securing to a metal fixture, self tapping "tek" screws may be more suitable.

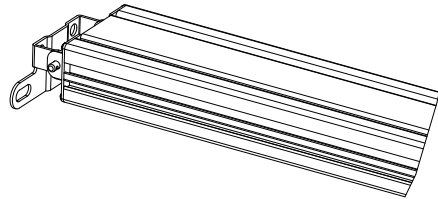
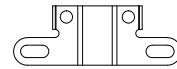

STEP 6

ATTACH RAIL TO HEADER BRACKET

Position the assembled operator on the floor below the header bracket. Use foam packing material as a protective base.

NOTE: If the door spring is in the way have someone hold the operator securely on a temporary support to allow the rail to clear the spring.

- Position the rail bracket against the header bracket
- Align the bracket holes and fit the two 6mm Clevis Pins (2) either side of the header bracket and secure with R Clips (3) on the outer side of the bracket.

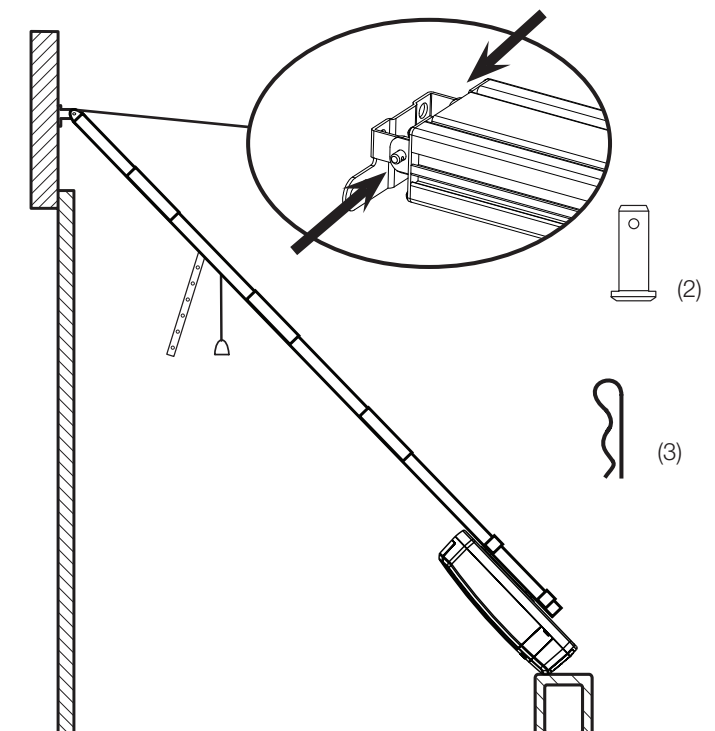

STEP 7

POSITION THE OPERATOR

Disengage the trolley mechanism (see section “Operating the manual release”) and slide it back towards the operator. Secure the hanging push arm up into the rail assembly temporarily using tape or rope, to avoid a hazard.

1. Raise the operator onto support (eg ladder)
2. Open the door completely, place a 50 mm spacer between the door and the rail (as shown)
3. The final positioning of the rail should be relatively parallel to the horizontal door panels.

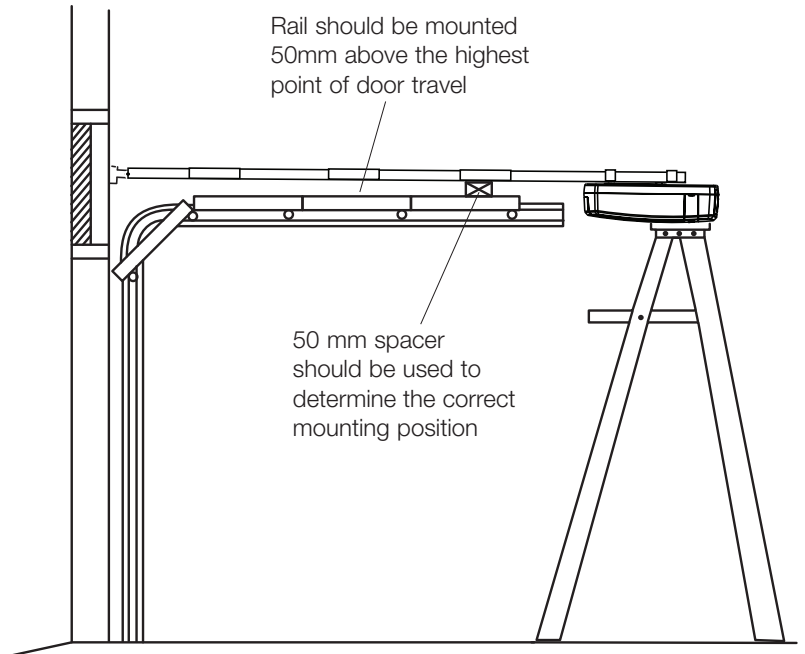

STEP 8

MOUNT THE OPERATOR TO THE CEILING

1. Position the operator as in the previous step. Check the rail is centred over the door. Ensure the hanging brackets are on the Operator end of the rail in a position as close to the operator as possible (1).
2. If hanging the operator below the ceiling, bend the hanging brackets provided, and secure to both the ceiling (2) and the rail mounting screws (3).
3. If mounting directly onto the ceiling, drill appropriate holes through the top of the rail. Use a minimum of 2 screws to fix to the ceiling. Screw the rail directly into a structural support on the ceiling (4). Ensure screw head height does not exceed 6mm (5) to avoid the screw head interfering with the trolley movement.
4. Check the operator is securely centred over the door. Remove the 50 mm spacer, and any other assembly tools. Operate the door manually and check for unrestricted operation.

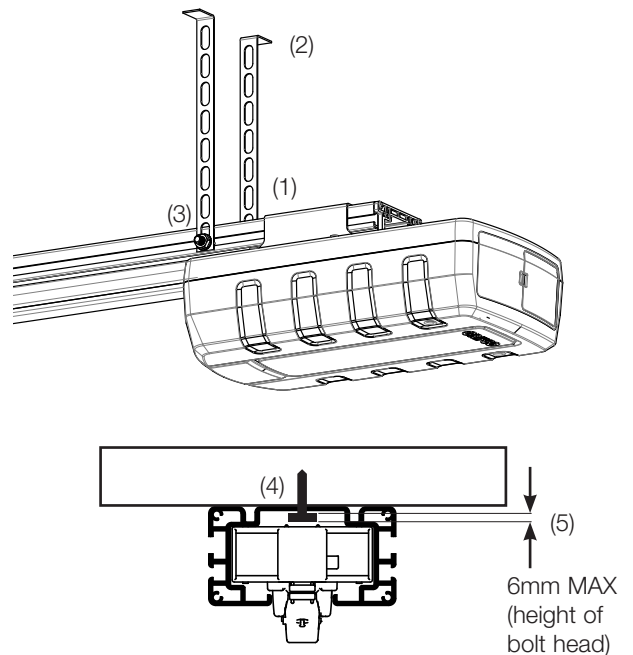

STEP 9

FASTEN THE DOOR BRACKET

The door bracket must be securely fastened to the frame or a structural support on the door.

Mounting position for Sectional Doors

1. Align the bracket on the centre line, measure down 100-300 mm from the door top edge.
2. Secure the bracket in this position, using the most suitable variation of holes available.

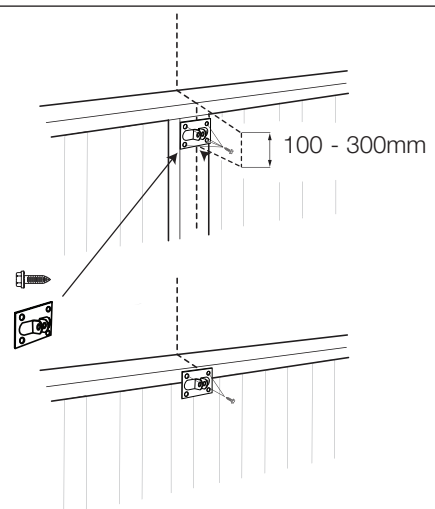

INSTALLATION

STEP 10

ATTACH DOOR ARM TO TROLLEY

Make sure the door is fully closed. Pull the manual release cord to disengage the trolley. Slide the trolley to around 300mm from the header bracket.

1. The Door Arm is already preassembled to the trolley.
2. Install the J-Bar onto the door bracket using the Clevis pin (1) and R-Clip (2) supplied.
3. Move the Door Arm and J-Bars together and secure using two bolts and nuts provided (3).
4. Ensure the angle of the Door Arm is around 20° from vertical, when the door is fully closed.

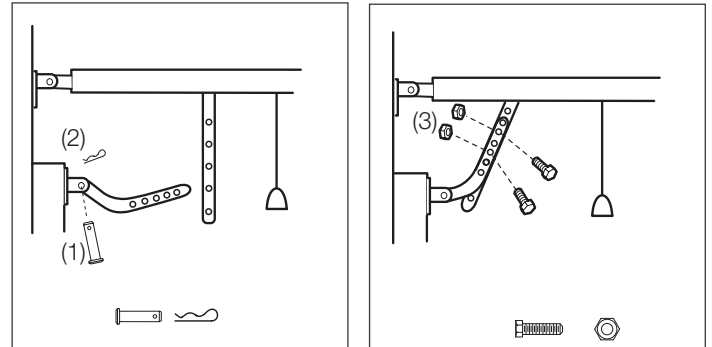

STEP 11

TESTING AND OPERATING THE MANUAL RELEASE

DO NOT DISENGAGE THE OPERATOR WITH CHILDREN, PERSONS OR OTHER OBJECTS INCLUDING MOTOR VEHICLES WITHIN THE DOORWAY.

(The door is under significant tension and if the door has developed a fault or incorrect tension, it may be unsafe and may fall rapidly.)

The manual release mechanism enables the door to be manually operated during power outages or in an emergency.

The RED Manual Release cord is preassembled to the trolley. When the operator is installed the handle should be no higher than 1.8 metres from the floor. The cord may need to be extended.

Attach the manual release Instruction Label around the cord as shown below.

DO NOT USE THE RED HANDLE TO OPEN AND CLOSE THE DOOR.

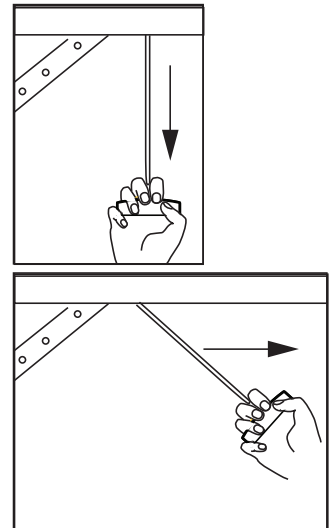

To operate the Manual Release. The door should be fully closed if possible.

1. Disengage: Pull the manual release rope and handle down to disconnect. This will disengage the trolley, allowing the door to be moved by hand, UP and DOWN as many times as needed.
2. Re-engage: Pull the manual release rope towards the motor until it springs back to its original horizontal position. This will re-engage the trolley, and when the door passes the trolley position it will automatically re-engage the operator.

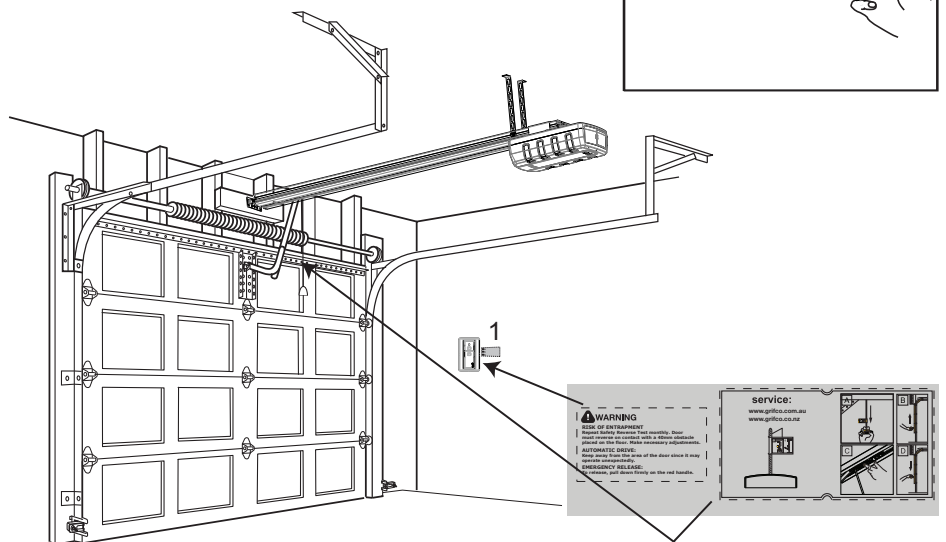

WARNING

Connect Electric Power

TO AVOID INSTALLATION DIFFICULTIES, DO NOT RUN THE DOOR OPERATOR UNTIL INSTRUCTED TO DO SO

Connect to properly fused and earthed power outlet.

- Ensure all ropes and installation tools have been removed from the door
- When the operator is switched ON, the operator light flashes a number of times and then remains ON.

STEP 12

PROGRAM THE TRAVEL LIMITS AND FORCE SETTINGS

Travel limits regulate the points at which the door will stop when moving UP or DOWN. The travel limit buttons are located under the access cover on the rear panel (Figure 1)

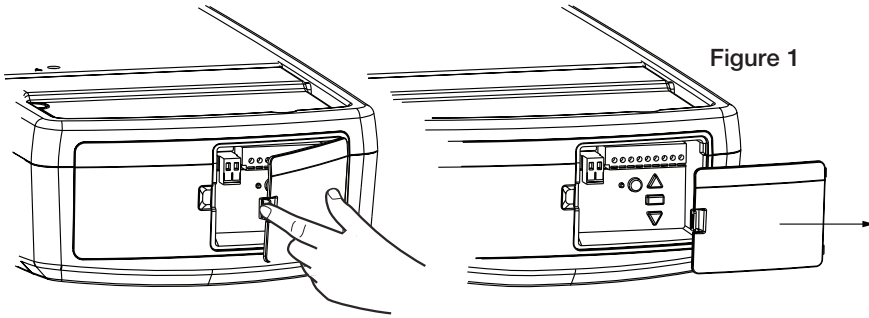

Figure 1

NOTE: This operator uses a POSITION TAB attached to the chain which activates a mechanical passpoint during the door travel. The indicator LED will blink when this occurs. If the passpoint is not activated during the door travel process, the travel limits can't be programmed.

TO PROGRAM THE TRAVEL LIMITS:

1. Press the PROG Button until the UP arrow button and indicator LED begin to flash (figure 2).
2. Press and hold the UP arrow button until the door is in the desired OPEN limit position (figure 3).

NOTE: The UP and DOWN Arrow Buttons can be used to move the door up and down as needed.

3. Once the door is in the desired OPEN limit position press and release the PROG Button. The DOWN Arrow Button will begin to flash (figure 4).
4. Press and hold the DOWN Arrow Button until the door is in the desired CLOSED position (fig 5).

NOTE: The UP and DOWN Arrow Buttons can be used to move the door up and down as needed.

5. Once the door is in the desired CLOSED limit position press and release the PROG Button. The UP Arrow Button will begin to flash (figure 2).

SETTING THE FORCE (AUTO):

6. Press and release the UP Arrow Button to test the OPEN limit. When the door has travelled to the programmed OPEN limit, the DOWN Arrow Button will begin to flash.
7. Press and release the DOWN Arrow Button to test the CLOSED limit. The door will travel to the programmed CLOSED limit position.

The indicator LED will stop flashing. The travel limits and force setting has now been set. Proceed to test safety reverse system.

SETTING THE FORCE (MANUAL LEARN IF REQUIRED):

1. Open the rear access panel. Locate the yellow Learn button.
2. Push the yellow Learn button twice to enter operator into force adjustment mode. The LED indicator light will flash quickly.
3. Push the programmed remote control or push the UP/DOWN arrow button on the control panel. The door will travel to the CLOSED limit position. Push the remote control again, the door will travel to the OPEN position.
4. Press and release the DOWN Arrow Button to test the CLOSED limit position. The door will travel to the programmed CLOSED limit position.

The LED indicator light will stop flashing when the force has been set. The door must travel through a complete cycle, UP and DOWN, in order for the force to be set properly. If the operator cannot open and close your door fully, inspect your door to insure that it is not sticking or binding.

The Force Setting has now been set manually.

WARNING

WHEN SETTING THE TRAVEL LIMITS, ENSURE PEOPLE ARE CLEAR OF THE MOVING DOOR TO AVOID INJURY.

Without a properly installed safety reversal system, persons (particularly small children) could be SERIOUSLY INJURED or KILLED by a closing door.

- Incorrect adjustment of door travel limits will interfere with proper operation of safety reversal system.
- NEVER use force adjustments to compensate for a binding or sticking door.
- After ANY adjustments are made, the safety reversal system MUST be tested. Door MUST reverse on contact with 40 mm high object laid flat on floor.

Safety Beams must be used for all installations. Installers should ensure that the doors are installed in a compliant manner as per AS/NZS 60335-2-103.

Safety Beams are not needed to perform the travel limits and force setting as described here.

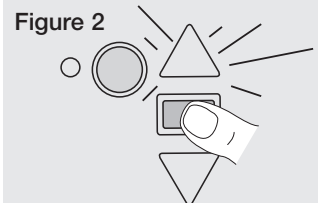

Figure 2

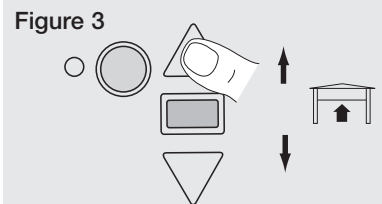

Figure 3

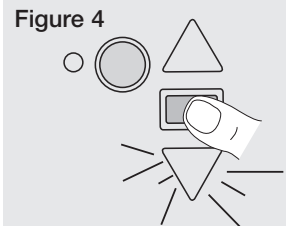

Figure 4

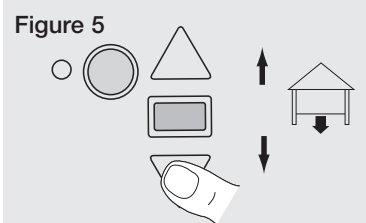

Figure 5

STEP 13

INSTALL THE ENTRAPMENT PROTECTION SYSTEM

NOTE: LS-Drive is supplied with a pair of monitored entrapment protection safety beams. They must be installed for the operator to function.

LS-Drive is also compatible with GPS15 Reflective Safety Beams, however it is not compatible with the GLCPS Light Curtain Protector System.

The Safety Beams are supplied preassembled, complete with two Safety Beams, wiring and wall brackets. (fig1 & fig2)

Install the mounting brackets and Safety Beams to either side of the inside of the door, and at a height of no greater than 100 mm off the floor.

The brackets are designed to be used for Wall or Floor fixing, with a variety of hole combinations to achieve the desired results.

Drill the required holes and install the brackets with wall plugs and screws provided. Ensure they do not obstruct the door movement.

Wiring Process:

Align the Safety Beams to face each other and tighten if necessary. The wiring should exit from the bottom of the housing to maintain the correct IP rating and continued operation.

One sensor is a Sending Eye, the other is a Receiving Eye. Try to avoid positioning these in direct sunlight as this may interfere with the operation of the beams.

Run both sets of wire back to the operator CONTROL PANEL. Use the channels provided on either side of the rail extrusion and secure with the 4 supplied cable clips to ensure cable does not come loose. Mount a cable clip at either end of the rail - and either side of the rail (figure 4)

Remove Power from the Operator:

At the Operator end, cut the wires to the correct length and strip each back around 10 mm.

Twist both White wires together and install into terminal 2 (White terminal) (fig 3)

Twist both Grey wires together and install into terminal 3 (Grey terminal) (fig 3)

The Safety Beams are a 2 wired system connected in a parallel configuration.

Reinstall Power to the Operator:

When aligned correctly the Red LED on each sensor will remain "ON constantly".

If incorrectly aligned both LEDs will "flash".

Correct the alignment if necessary.

The operator is now ready to be checked for correct IR Beam operation.

Test Operation

Press the Up button in the Control Panel and check the door travels smoothly to the open limit position.

If there are no issues detected, press the Down button and check the door travels to the closed limit position. Open and close the door again, and obstruct the IR beam while closing to check the door stops and reverses to the open limit position.

If the door and operator are functioning correctly proceed to the next step.

WARNING

To prevent entrapment, install The Safety Beams no higher than 100 mm above the floor.

Disconnect power to the operator before installing the safety beams.

Figure 1

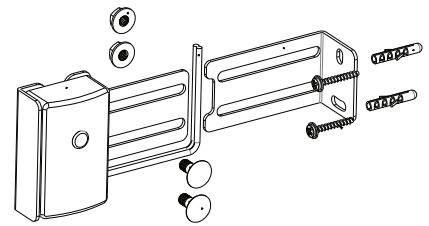

Figure 2

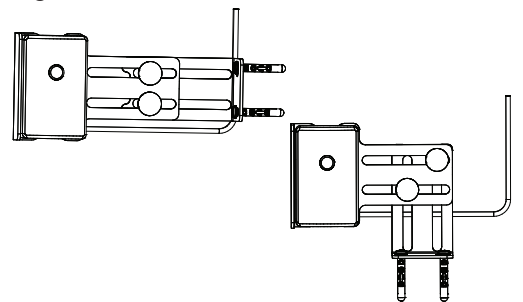

Figure 3

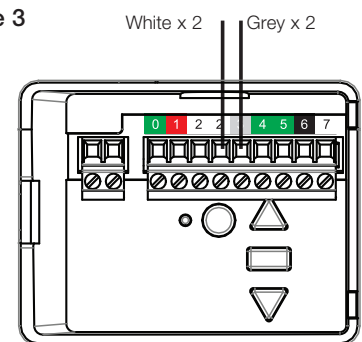
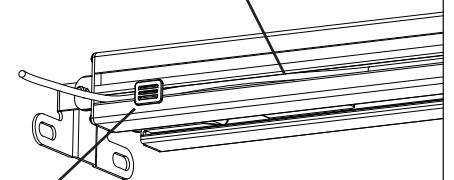

Figure 4

Channels for safety beam cables

Cable clip



STEP 14

SETTING TIMER-TO-CLOSE

Operation:

This feature allows the door to automatically close from a fully open position after a specified time. The delay can be set from 10 to 180 seconds in 10 second increments, by using the buttons on operator control panel.

If the door encounters an obstruction while closing, the door will stop and return to the OPEN limit position. The LED indicator light will then flash 10 times.

To Activate TTC, or change a preset time:

1. Start with the door fully CLOSED.
2. Enter into TTC Activation mode by pressing both PROG and DOWN buttons together for 3 seconds (figure 2). Release when the LED indicator light flashes twice.
3. Press the UP button once for each 10 second increment required of TTC (figure 3. eg. twice for 20 seconds). Press the DOWN arrow button to reduce, if needed.
4. Press and release the PROG button to save this time (figure 4), LED indicator light will flash once. TTC is now activated.

TEST: Operate the door to the OPEN limit position. Keep clear of the Safety Beams and check the door closes after the preset time.

When TTC is set, wireless transmitters and wired trigger inputs will send an "open-only" command to the operator.

To Deactivate TTC:

1. Enter into TTC Activation mode by pressing both PROG and DOWN buttons together for 3 seconds (figure 2). Release when the LED indicator light flashes twice.
2. Press and release the PROG button to save (figure 4), LED indicator light will flash once. TTC is now deactivated.

! WARNING

Door may operate unexpectedly, therefore do not allow anything to stay in the path of the door.

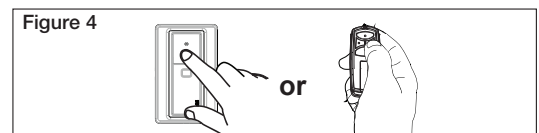
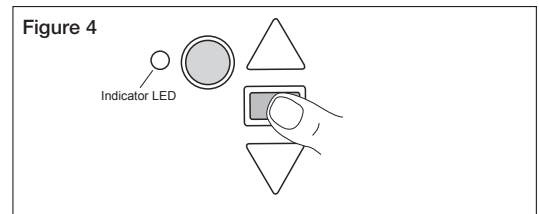
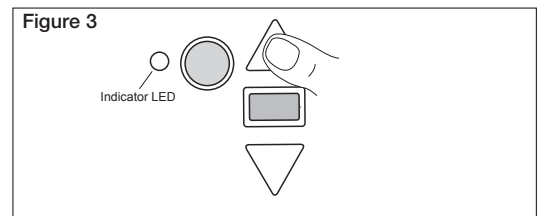
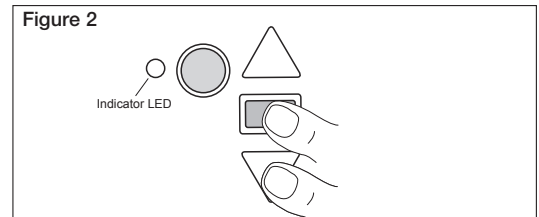
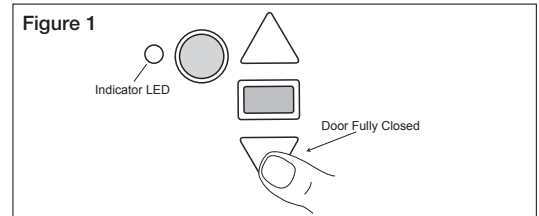

STEP 15

ATTACHING BATTERY BACKUP UNIT (OPTIONAL)

LS-Drive is compatible with the separate Grifco Battery Backup accessory GLD-BBU24V. The BBU should be attached after the LS-Drive has been installed.

1. TURN MAINS POWER OFF BEFORE PROCEEDING
2. Remove plugs on either side of the BBU to reveal mounting holes.
3. Mount the BBU to the ceiling, wall or on top of the rail.
4. Plug the BBU into the operator's BBU socket, located on top of the operator, near where the power cord is connected
5. Turn mains power back on
6. Unit will now function under BBU power. BBU will automatically charge and remain fully charged
7. Operate the door with and without mains power connected to test BBU functionality.

BBU Wall or Ceiling Mounting Instructions

Remove the plugs from the BBU screw holes. Mount the BBU to the wall or ceiling using the 2 screws provided. Ensure that the screws are secured to a structural part of the wall or ceiling

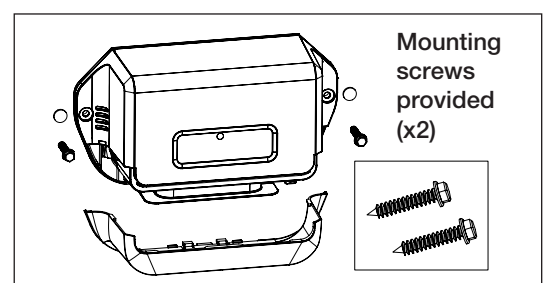
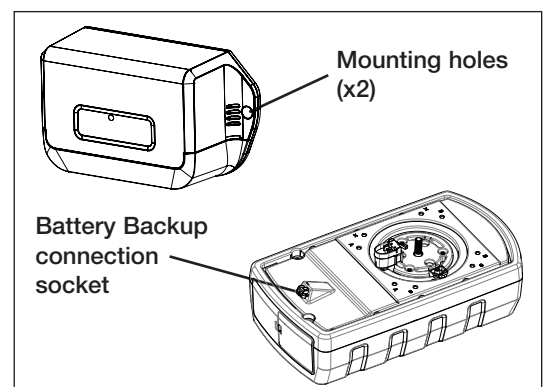

STEP 16

COMMISSIONING REMOTE ACCESS DEVICES

NOTE: The transmitter supplied with your operator is preprogrammed by the factory.

Program the Receiver to Match Additional Transmitter Codes:

Using the yellow "LEARN" Button

1. Press and Hold the button on the hand-held remote or wall button that you wish to use (1).
2. Press and release the yellow "LEARN" button on the operator (2).
3. Release the remote button. When the LED indicator flashes the operator has learned the code. If you release the remote control push button before the operator light flashes, the operator will not learn the code.

Now the operator will activate when the remote control push button is pressed.

To Erase all Remote Control Codes

1. Press and Hold the yellow "LEARN" button on the operator until the indicator LED goes ON, and continue holding for approx. 6 seconds, until the indicator LED goes out.
2. Release the button, all codes are now erased.

Wireless Keypad E840G

To set the keyless entry PIN:

1. Locate the yellow "LEARN" button on the door operator.
2. Press and release the yellow "LEARN" button. The LED indicator light will glow steadily.
3. Enter a 4-digit personal identification number (PIN) of your choice on the keypad.
4. Press and hold the ENTER button. Check to see if the operator light flashes. Release the ENTER button after the light flashes.

To change an existing keyless entry PIN:

1. Enter the existing programmed PIN that you want to change.
2. Press and hold the # button until the LED indicator light flashes twice.
3. Enter the new 4-digit PIN of your choice, then press the ENTER button. The light will flash once.
4. To test, enter the new PIN, then press the ENTER button. The operator will activate.

! WARNING

Activate the operator only when door is in full view, free of obstruction and properly adjusted. No one should enter or leave garage while door is in motion. Do not allow children to operate push button(s) or remote(s). Do not allow children to play near the door.

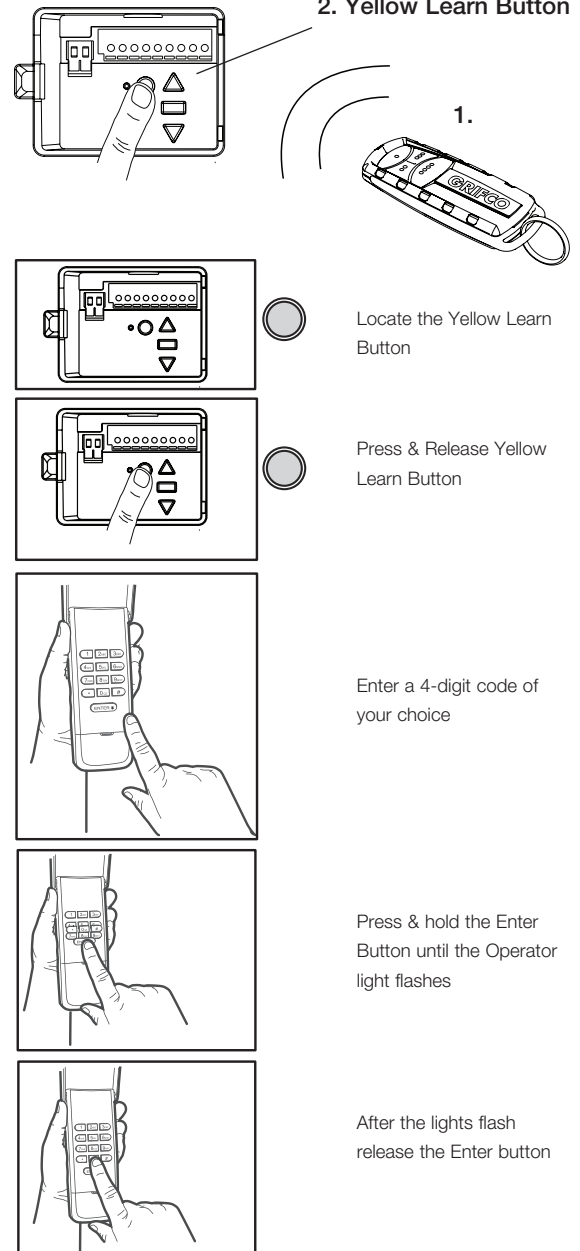

STEP 17

COMMISSIONING myQ

myQ INTERNET GATEWAY (not provided)

LS-Drive is compatible with Chamberlain Group's myQ connectivity feature. You will need a broadband internet connection to use the Internet Gateway.

Grifco Monitored Entrapment Protection is required to enable myQ control. Refer to page 5 for wiring details and refer to the safety device's manual for more information.

PROGRAMMING myQ

Please refer to the myQ manual supplied with the Internet Gateway.

myQ
MyQ Internet Gateway
Model: G828AU



STEP 18

COMMISSIONING FIRE OPEN INPUT

Activation of the Fire OPEN Input will hold an open door open, or open a closed or closing and hold the door at the fully open position. While the Fire OPEN Input is active, all other inputs or commands will be ignored. When the Fire OPEN Input is released, the opener will respond to other commands, including Timer-To-Close, allowing the door to close.

Wiring Process:

Connect the N/O Fire Signal to Terminals 1 and 2.

Test Operation

Activate the Fire OPEN Input and latch. After three seconds, the opener will drive the door to the OPEN position and hold open.

Test the operation using a transmitter or other close command. The door will remain open, and the Control Panel will now display a 5-1 diagnostic code.

Release the Fire OPEN Input. Test the operation using a transmitter or other close command. The opener will now drive the door to the CLOSED position.

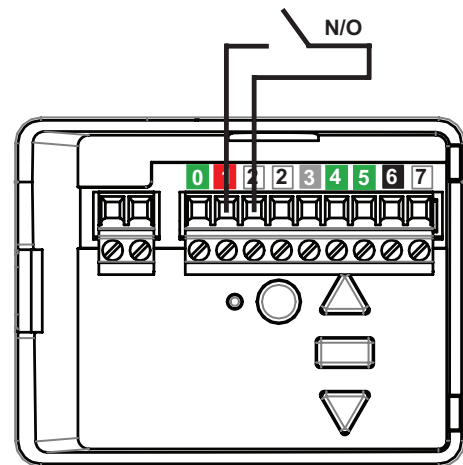

MAINTENANCE AND CARE

USING YOUR OPERATOR

1. Your operator can be activated by any of the following devices:

- Operator control panel: Up and Down Buttons
- The Outside Keyswitch or Keyless Entry System (if you have installed either of these accessories).
- The Remote Control Transmitter. Hold the push button down until the door starts to move.

2. Opening the Door Manually: DOOR SHOULD BE FULLY CLOSED IF POSSIBLE. Weak or broken springs could allow an open door to fall rapidly. Property damage or serious personal injury could result.

The door can be opened manually by pulling the release handle down. To reconnect the door, pull the manual release rope towards the motor until it springs back to its original horizontal position.

Do not use the manual release handle to pull the door open or closed.

3a. When TTC is not set.

When the Operator is Activated by Remote Control:

1. If open, the door will close. If closed, the door will open.
2. If closing, the door will stop.
3. If opening, the door will stop.
4. If the door has been stopped in a partially open or closed position, it will reverse direction.
5. If an obstruction is encountered while closing, the door will reverse to the OPEN limit position.
6. If an obstruction is encountered while opening, the door will stop and reverse for a short distance.
7. The Safety Beam uses an invisible beam which, when broken by an obstruction, causes a closing door to open and prevents an open door from closing.

3b. When TTC is set.

When the Operator is Activated by Remote Control:

1. If open, the door will not move, but the timer will reset
2. If closing, the door will stop and open.
3. If opening, the door will continue towards the open limit.
4. If the door has been stopped in a partially open or closed position, it will open.
5. If an obstruction is encountered while closing, the door will open.
6. If an obstruction is encountered while opening, the door will stop and reverse for a short distance.
7. The Safety Beam uses an invisible beam which, when broken by an obstruction, causes a closing door to open and prevents an open door from closing.

4. The operator lights will turn on under the following conditions: when the operator is initially plugged in; when power is restored after interruption or when the operator is activated. Lights will turn off automatically after 2-1/2 minutes.



WARNING

Before opening the door manually, ensure door is at its CLOSED limit position if possible.

CARE OF YOUR OPERATOR

Once a Month

- Disconnect power cord when performing service or maintenance.
- Manually operate door. If it is unbalanced or binding, call a qualified door technician.
- Check to be sure door opens & closes fully. Adjust limits and/or force if necessary.

Once a Year

- Disconnect power cord when performing service or maintenance.
- Internally the operator does not require additional lubrication.
- Lightly grease the chain and inside the rail assembly where the trolley slides. Be careful to use gloves around any sharp metal edge or the rail.

BATTERY OF THE TRANSMITTERS:

The batteries in the transmitter have a long life.

If the transmission range decreases, the batteries should be replaced. Batteries are not covered by the warranty.



WARNING! This product contains a button/coin cell battery.

- **The battery is hazardous.**
- **Keep new and used batteries away from children.**
- **Do not ingest battery. Chemical burn hazard.**
- **If the coin cell battery is swallowed or placed inside any part of the body, it can cause severe or fatal injuries in 2 hours or less.**
- **If the battery compartment does not close securely, stop using the product and keep away from children.**
- **If you think batteries might have been swallowed or placed inside any part of the body, call the 24-hour Poisons Information Centre on 13 11 26 in Australia, or the 24-hour National Poisons Centre on 0800 764 766 in New Zealand, or seek immediate medical attention.**
- **Dispose of used coin/button cell batteries immediately and safely. Flat batteries can still be dangerous.**

Replacing battery (CR2032 or equivalent):

To replace the battery, turn the transmitter around and open the case with a screwdriver. Lift the cover and lift the control board. Slide the battery to one side and remove the old battery. Be sure to observe the polarity of the battery.

Assemble the transmitter again following the steps in reverse.

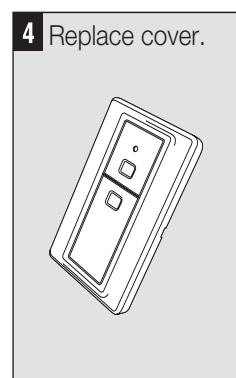
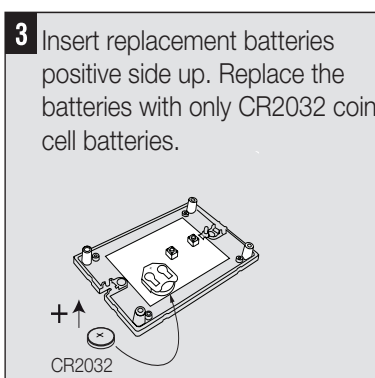
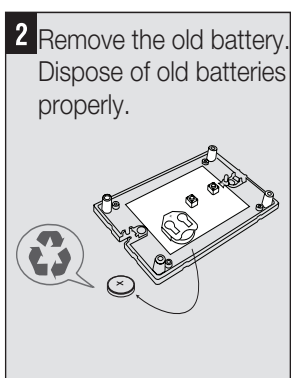
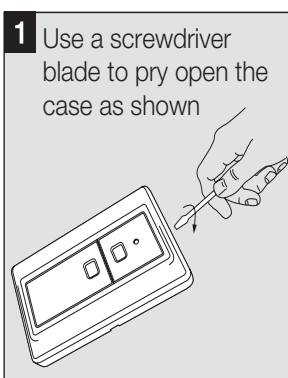
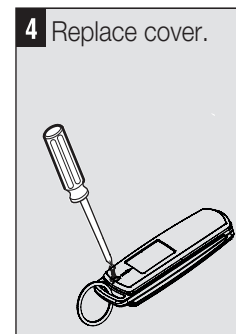
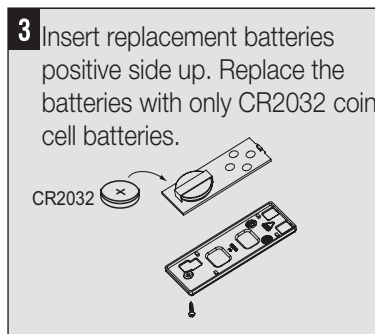
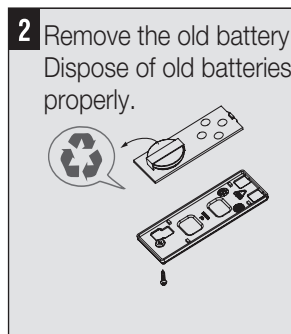
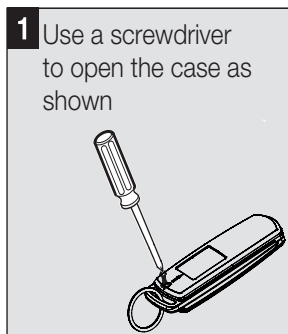

ACCESSORIES

TYPES OF SECURITY +2.0 REMOTE ACCESS DEVICES

All Grifco remote access devices feature Security +2.0 technology. This advanced platform cuts through interference, and ensures consistent, reliable, long range operation of your commercial door.

With inbuilt perpetual rolling code technology, Grifco Security +2.0 transmitters are safe and secure. All devices feature exceptional battery life, easy configuration and long range.

E960G

4-Channel Keyring Transmitter



STAR1000EVO

Transmitter Management Device



E138G

2-Channel Wall Transmitter



E840G

Wireless Security Keypad



TROUBLESHOOTING

TROUBLESHOOTING

1. Operator doesn't operate from either door control or remote:

- Does the operator have electric power? Plug lamp into outlet.
- If it doesn't light, check the fuse box or the circuit breaker. (Some outlets are controlled by a wall switch.)
- Have you disengaged all door locks? Review installation instruction warnings on page 1.
- Is there a build-up of ice or snow under door? The door may be frozen to ground. Remove any obstruction.
- The door spring may be broken. Have it replaced.
- The Fire OPEN Input has been activated, Check for 5-1 error code.

2. Door operates from door control but not from remote:

- Replace batteries in the remote if necessary.
- If you have two or more remotes and only one operates, review Program Your Operator, Remote and Keyless Entry.

3. Remote has short range:

- Check the battery in the remote is fully charged.
- Change the location of the remote control in the car.
- A metal door, foil-backed insulation or metal siding will reduce the transmission range.

4. Door reverses for no apparent reason and operator light flashes 10 times:

- Check Safety Beams. If the light on the Safety Beams is flashing, correct the alignment.
- NOTE: Operator will not close without Safety Beams connected.

5. The door opens and closes by itself:

- Make sure remote push button is not stuck "on".

6. Door stops but doesn't close completely:

- Repeat Programming the Travel Limits
- Repeat safety reverse test after any adjustment of door arm length, close force or down limit adjustments.

7. Door opens but won't close:

- Check Safety Beams. If the light on the Safety Beams are flashing, correct the alignment.
- If operator light does not flash and it is a new installation, repeat Programming the Travel Limits.

8. Operator strains:

- Door may be unbalanced or springs are broken.
- Close door and use manual release rope and handle to disconnect trolley.
- Open and close door manually.
- A properly balanced door will stay in any point of travel while Being supported entirely by its springs. If it does not, call for professional garage door service to correct the problem.

9. Operator hums briefly, then won't work:

- Garage door springs are broken. SEE ABOVE.
- If problem occurs on first operation of operator, door is locked. Disable door lock.
- Repeat safety reverse test after adjustment is complete.

10. Operator won't activate due to power failure:

- Pull manual release rope and handle down to disconnect trolley.
- Door can be opened and closed manually.
- When the power is restored, pull the manual release rope back towards the motor until it springs back to its original horizontal position. The next time the operator is activated, the trolley will re-connect.
- The Outside Quick Release accessory (if fitted) disconnects the trolley from outside the garage in case of power failure.

11. The operator runs, but the carriage does not move:

- Check the carriage is not disengaged from the operator
- Operate the manual release to reengage the operator.
- In a new installation, the preassembled Motor Shaft Adapter may have fallen out of the chain sprocket assembly. This adapter is installed during the manufacturing process and may have dislodged.

12. The Up and DOWN arrow buttons on the control panel are flashing in sequence:

- Check the diagnostic code on next page.

DIAGNOSTICS

The operator is programmed with self-diagnostic capabilities. The UP and DOWN arrows on the control panel indicate the diagnostic code.

DIAGNOSTIC CODE		SYMPTOM	POSSIBLE RESOLUTION
UP Arrow Flashes	DOWN Arrow Flashes		
1	1	The operator will not close and the courtesy light flashes.	Safety sensors wires may have been reversed, cut or disconnected. Inspect the sensor wires for correct polarity, damage or disconnections.
1	2	The operator will not close and the courtesy light flashes.	There is a short circuit on the wires for the safety sensors. Inspect safety sensor wire at all staple points and connection points and replace wire or correct as needed.
1	4	The operator will not close and the courtesy light flashes.	Safety sensors are misaligned or were momentarily obstructed. Realign both sensors to ensure both LEDs are steady and not flickering. Make sure nothing is hanging or mounted on the door that would interrupt the sensors path while closing.
1	5	There is no door movement or motor accelerates before stopping suddenly.	No RPM pulses have been detected. Check the door manually for balance, binding or obstructions. Internally the possible cause may be the motor, logic board or RPM sensor. Try resetting door travel limits. Contact service centre.
1	6	Door continues to move after the motor stops.	RPM pulses have been detected after motor has turned off. Possible broken spring. Check the door is correctly balanced and not creeping up or down. Contact a door service centre.
2	1 2 3 4 5	Operator fails to operate.	Possible logic board failure. Reboot operator by turning the mains power OFF and then ON after 15 seconds. Reprogram the door travel limits and force settings. Contact service centre.
2	6	Unable to set travel limit down direction. Passpoint has not been recognised during programming.	Check the passpoint module has been activated by the chain Position Tab, during the door travel. Reset the travel limits.
4	1 2 3 4	Door is moving stops and or reverses.	Manually open and close the door. Check for binding or obstructions, such as a broken spring or door lock. If the door is binding or sticking contact a trained door systems technician. If door is not binding or sticking attempt to reprogram travel (refer to "Program the Travel Limits and Force" section).
5	1 2 3 4	Operator fails to operate. Operator operates erratically. External accessory wiring failure.	Fire OPEN Input has been activated. Check the Fire Input (terminals 1 & 2). Check the external wiring to the control panel terminal is wired correctly. Turn off power, remove all external wiring (except safety sensors), and retest door operation.
5	5	Operator fails to operate	Low internal voltage on the Logic Board, possible power transformer or logic board failure. Service required, call a trained service specialist.

SERVICE AND REPAIR PARTS



If the supply cord is damaged, it must be replaced by the manufacturer, its service agent or similarly qualified persons in order to avoid hazard.

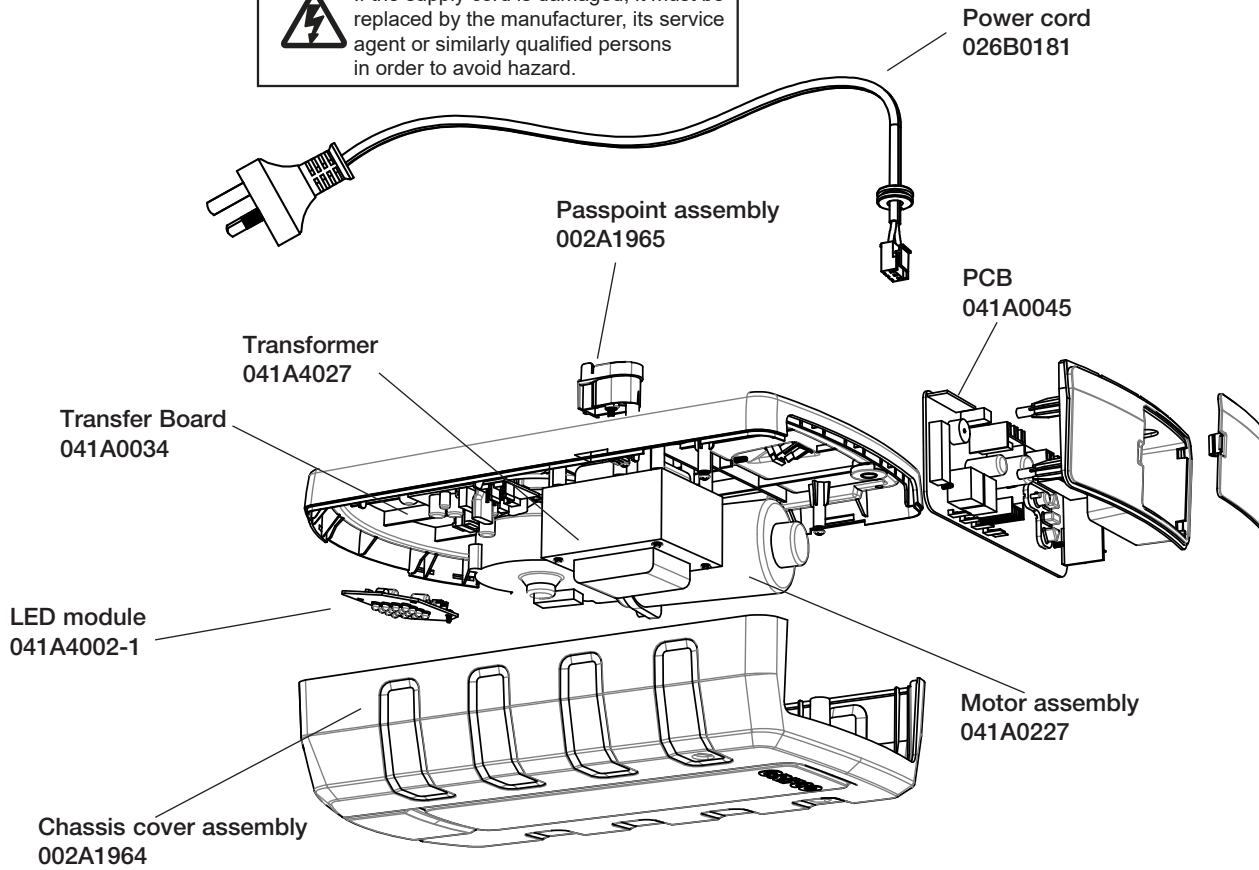

Rail Replacement Parts

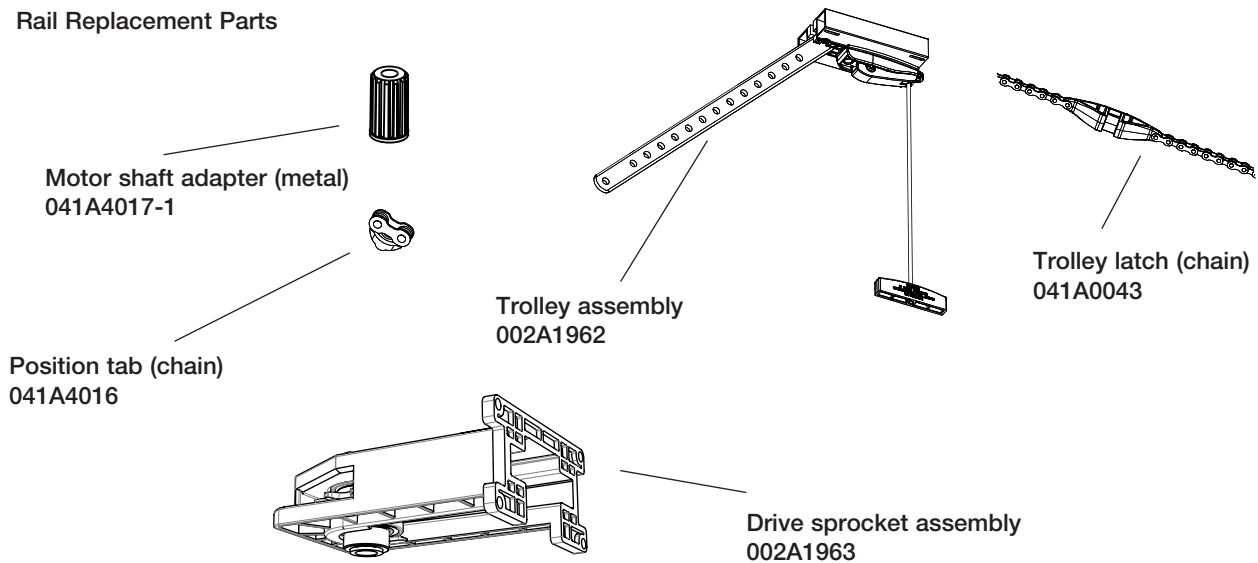

CHAMBERLAIN LIMITED WARRANTY - GRIFCO PRODUCTS

Chamberlain Australia Pty Limited / Chamberlain New Zealand Limited (Chamberlain) is committed to manufacturing and supplying high quality goods. As part of this commitment, we seek to provide reliable service and support for our goods and are pleased to provide you, the original purchaser, with this Chamberlain Limited Warranty.

We also provide the following statement as required by the Australian Consumer Law: In Australia, in addition to your rights under this Chamberlain Limited Warranty, our goods come with guarantees that cannot be excluded under the Australian Consumer Law. You are entitled to a replacement or refund for a major failure and for compensation for any other reasonably foreseeable loss or damage. You are also entitled to have the goods repaired or replaced if the goods fail to be of acceptable quality and the failure does not amount to a major failure.

Chamberlain's warranty

Chamberlain warrants to the original purchaser of the Grifco product (Unit) that:

- 1 The LS-Drive Unit (including electric motor) is free from defects in materials and workmanship for a period of 24 months from the date of purchase or 20,000 cycles (whichever comes first).
- 2 During the applicable Chamberlain Warranty period, if you are concerned that the Unit or electric motor may be defective, call our service centre on the toll free number below before removing the Unit and a Chamberlain technician will diagnose the problem. Once the problem has been diagnosed, subject to your rights under the Australian Consumer Law with respect to major failures,

Chamberlain will provide you with:

- 1 parts for "do-it-yourself" repairs; or
- 2 shipping instructions for a factory repair or replacement.
If a factory repair or replacement is required, provided the defective part or Unit is returned to Chamberlain well-packaged and in accordance with Chamberlain's shipping instructions,

Chamberlain will, subject to your rights under the Australian Consumer Law with respect to major failures in relation to the Unit, repair or, at its option where permissible, replace any defective part or Unit and return it to you at no cost; and

Exclusions

If our service centre determines that a warranty claim has been made in respect of a failure or defect arising under or out of any exclusion detailed below such that the claim is not covered under this Chamberlain Limited Warranty, we may, subject to your other rights and remedies as a consumer, charge you a fee to repair, replace and/or return the Unit to you.

This Chamberlain Limited Warranty does not cover any failure of, or defect in, the Unit due to:

- 1 non-compliance with the instructions regarding installation, operation, maintenance and testing of the Unit or of any product with which the Unit is used;
- 2 any attempt by a person other than an authorised installer to change settings, repair, dismantle, reinstall or move the Unit to another location once it has been installed;
- 3 tampering, neglect, abuse, wear and tear, accident, electrical storm, excessive use or conditions other than normal commercial use;
- 4 use of the Unit in conjunction with controls which have not been supplied, or pre-approved, by Chamberlain;
- 5 problems with, or relating to, the commercial door or commercial door hardware, including but not limited to the door springs, door rollers, door alignment, hinges, guides, slats and drums; or
- 6 problems caused by electrical faults.

If this Chamberlain Limited Warranty does not apply, you may have rights available to you under the Australian Consumer Law.

Liability – Australia only

Except as set out in the Australian Consumer Law (being Schedule 2 of the Competition and Consumer Act 2010) (as amended, consolidated or replaced):

- 1 all other guarantees, warranties and representations in relation to the Unit or its supply are excluded to the extent that Chamberlain can lawfully exclude them; and
- 2 under no circumstances will Chamberlain be liable for consequential, incidental or special damages arising in connection with the use, or inability to use, the Unit, other than those which were reasonably foreseeable as liable to result from the failure.

Liability – New Zealand only

Except as set out in the Fair Trading Act 1986 and the Consumer Guarantees Act 1993 (as amended, consolidated or replaced):

- 1 all other guarantees, warranties and representations in relation to the Unit or its supply are excluded to the extent that Chamberlain can lawfully exclude them; and
- 2 under no circumstances will Chamberlain be liable for consequential, incidental or special damages arising in connection with the use, or inability to use, the Unit, other than those which were reasonably foreseeable as liable to result from the failure.

Note

We request that you retain your sales docket or invoice as proof-of-purchase and attach it to this manual to enable you to establish the date of purchase in the unlikely event of a warranty service being required. Chamberlain reserves the right to change the design and specifications of the Unit without prior notification. Some features or accessories of the Unit may not be available in certain markets or areas. Please check with your distributor.

Chamberlain service centre contact details Australia

Phone toll free 1800 474 326

Fax toll free 1800 888 121

Unit 1, 75 Epping Road North Ryde, NSW 2113

Email customerservice@chamberlainanz.com

New Zealand

Auckland phone 09 477 2823

Phone toll free 0800 653 667

Fax toll free 0800 653 663

Website www.grifco.com.au or www.grifco.co.nz